	INDIAN SCHOOL AL WADI AL KABIR	
Class: XII	Department: SCIENCE – 2022-2023 SUBJECT: <u>ENGINEERING GRAPHICS</u>	Date of Completion: 06.06.22
Worksheet No:2 With Answers	Topic: MACHINE DRAWING	Note: A4 FILE FORMAT
NAME OF THE STUDENT:	CLASS: XII SECTION:C	ROLL NO:

- 1.Draw to 1:1 the front elevation and side view of a hexagonal head bolt of M30 size,keeping the axis horizontal.Give standard dimensions.
- 2.Draw to scale 1:1 the standard profile of a BSW thread ,taking enlarged pitch = 30 mm,Give standard dimensions.
- 3.Draw to scale 1:1 the standard profile of a metric thread (internal) taking enlarged pitch = 60 mm,Give standard dimensions.
- 4.Draw to scale 1:1 the front view and top view of a square head bolt of diameter 26 mm,keeping its axis vertical.
- 5.Sketch freehand, front view and side view of a stud with collar,keeping the axis vertical.Give standard dimensions.
- 6.Sketch freehand the front view and top view of a flat head rivet of diameter 20 mm,keeping its axis vertical.Give standard dimensions.

MULTIPLE CHOICE QUESTIONS

- 1.The distance moved by a nut or bolt in the axial direction in one complete rotation is called as-----
a) Pitch
b)Lead

c) crest

d) None of the above

2. The machine parts which can be separated only breaking the fastening is called as-----

a) Temporary fastener

b) Permanent fastener

c) Screw thread

d) Screw pair

3. A helical groove cut along the outer circumference of a cylinder is called a -----

a) Fastener

b) Nut

c) Bolt

d) Screw thread

4. The nut and bolt together is called as -----

a) Screw pair

b) Fastener

c) Nut

d) Bolt

5. The surface connecting crest and root is called as -----

a) Flank

b) Root

c)Lead

d)Pitch

6.Which type of thread is used in the neck of glass bottles -----

a)BSW thread

b)Metric thread

c) Knuckle thread

d) Square thread

7.In BSW thread the major diameter D is calculated using the formula?

a) $D = 0.96P$

b) $D = 0.86P$

c) $D = 0.64P$

d) $D = 0.61P$

8.----- is also called as unified thread

a.Knuckle thread

b. Metric thread

c.Taper thread

d. Square thread

9. Which one is a permanent fastener-----

a) Nut

b) Bolt

c) Rivets

d) Washer

10. A circular plate which provides a smooth bearing surface is called as -----

a) Nut

b) Bolt

c) Washer

d) None of the above

11. Nuts will have which type of threads-----

a) Internal threads

b) External threads

c) V threads

d) None of the above

ANSWERS

MULTIPLE CHOICE QUESTIONS

1. b) Lead
2. b) Permanent fastener
3. d) Screw thread
4. a) Screw pair
5. a) Flank
6. c) Knuckle
7. a) $D = 0.96P$
8. b) Metric thread
9. c) Rivets
10. c) Washer
11. a) Internal threads

SOLUTIONS FOR DRAWINGS

1. (Hint : standard dimensions of hexagonal headed bolt should be calculated in terms of d)

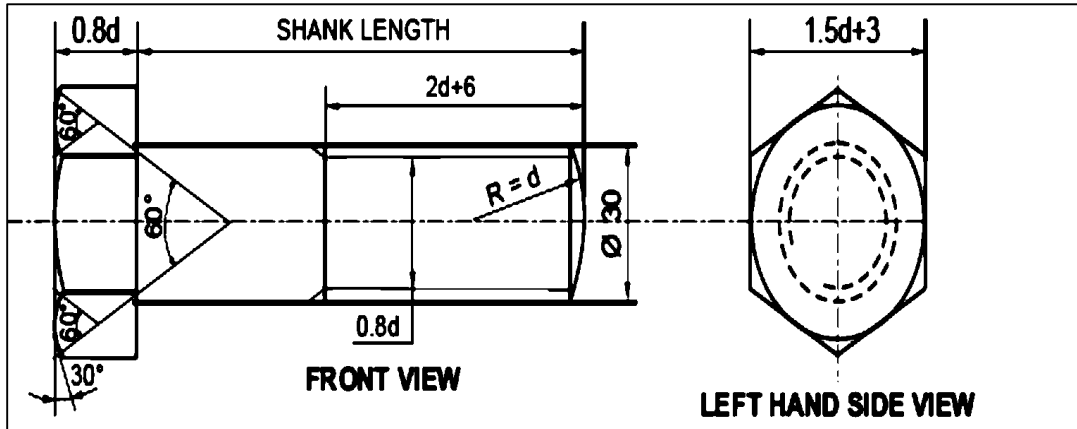

2. (Hint : Standard dimensions of BSW thread should be calculated with the pitch given = 30mm)

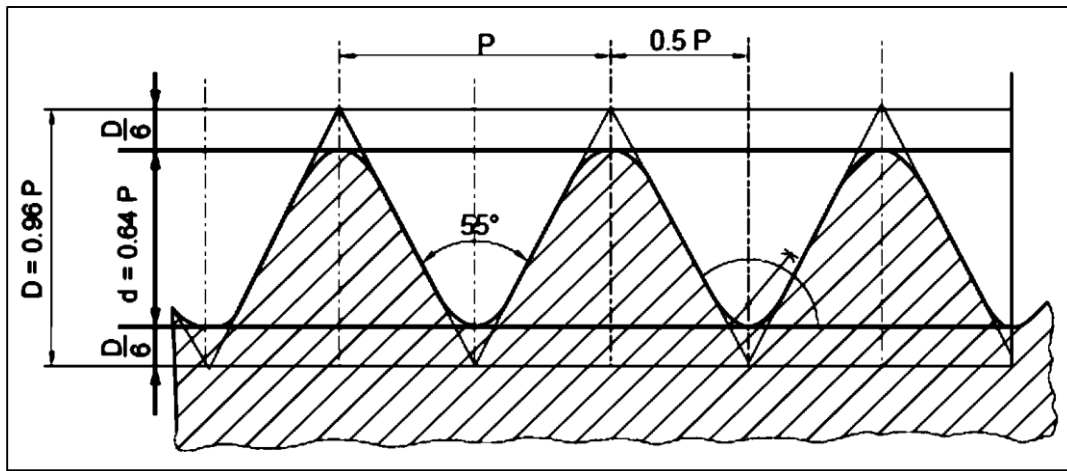

3. (Hint : Standard dimensions of Metric thread internal should be calculated with the pitch given = 60mm)

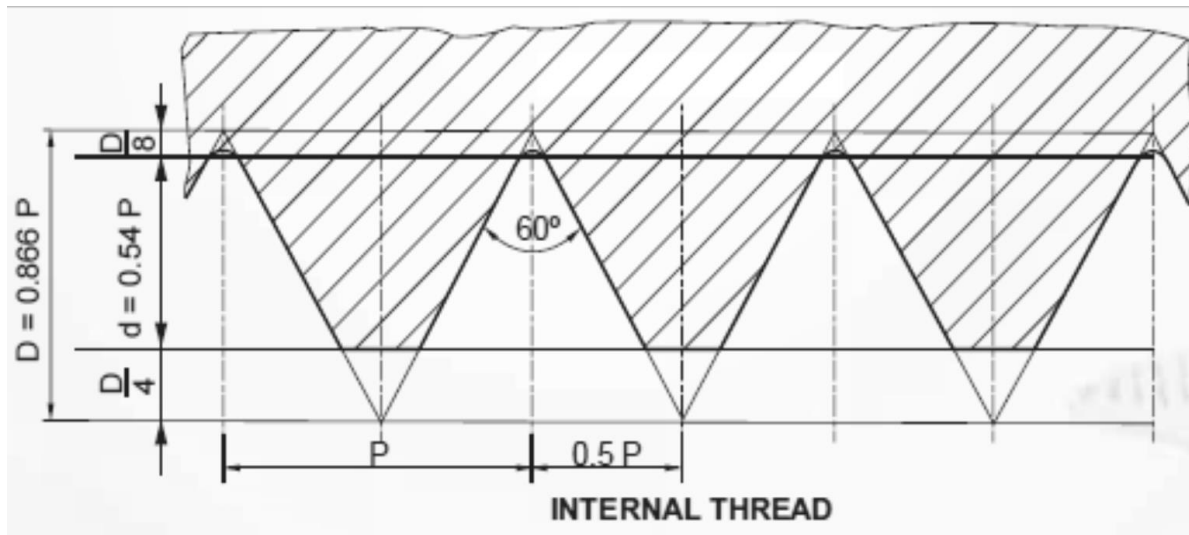

4. (Hint : Standard dimensions of square headed bolt in terms of d , $d = 26$ mm)

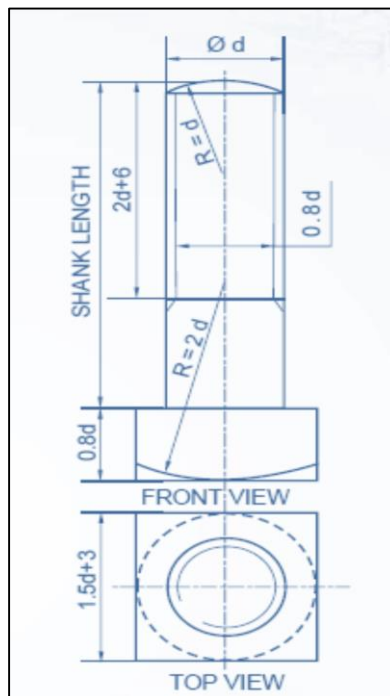

5. (Hint : Free hand sketch of stud with collar , d can be taken proportionately and calculate standard dimensions) .

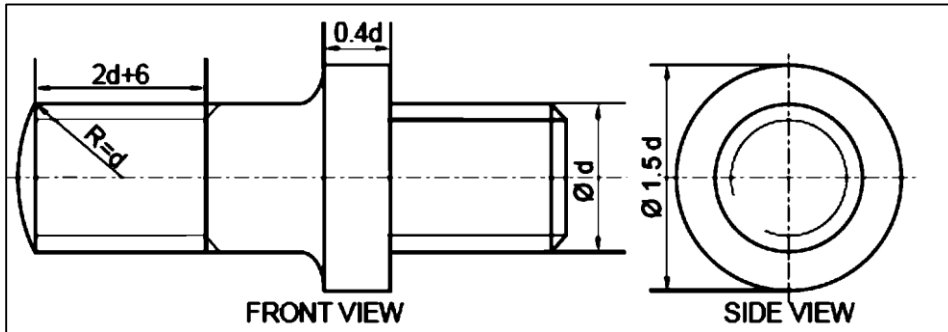

6. (Hint : Free hand sketch of flat head rivet ,stand dimensions calculated with $d = 20$ mm).

